



ENFIS UNO Plus Dome Array RGBW (Vivid Blue)

Rich RGBW spot-source colour/CCT changing with 36 high-power LED's in just 1cm²

Features & Benefits

- Intense, high-power RGBW spot source
- Superior colour-mixing via dense packaging and interleaving of colours
- Addition of white channel gives wide range of high quality white light and higher lumen than RGB
- Enables active monitoring of light output via embedded smart array technology
- Long-life and reliable, high-performance due to excellent thermal conductivity
- Simple integration via connectorized PCB with mounting holes

Outline Specification

- Typical power:
 - R: 500 Lumens
 - G: 570 Lumens
 - B: 110 Lumens
 - W: 550 Lumens
- >1500 Lumens (all channels on)
- 1.15cm² Aperture
- Input Power: 50W
- Typical thermal resistance <0.8°C/W

Light Engine Integration

Enfis can eliminate the time, cost and risk of integration by offering our arrays as part of a complete light engine solution

Smart Array Technology

Light output from the Enfis arrays can be monitored and controlled via patent-pending integrated photo-detection system, enabling precise control of light output.

Thermal Management

Enfis arrays are designed to provide excellent thermal conductivity and to be integrated effectively with thermal hardware to ensure optimum performance and life

Optics

Enfis Uno arrays provide excellent spot source with Lambertian emission characteristics. Enfis technical experts can advise a range of optical solutions to match your requirements.

Power Management

Enfis provides a range of feature-rich, powerful drivers and power supplies for our arrays. Our applications team can provide you with a solution for your specific requirements.

Applications & Markets

- Architectural lighting
 - Exterior buried spotlights
 - Exterior floodlights
 - Exterior/interior wall-washing
 - Interior colour/CCT-variable lighting
- Entertainment lighting
 - Club/bar lighting
 - Theatre spot gel replacement
 - Moving spots
- Retail lighting
 - Colour/CCT-variable spotlights
 - Display lighting
- Fibre optic lighting
 - Colour/CCT-changing illuminator light sources

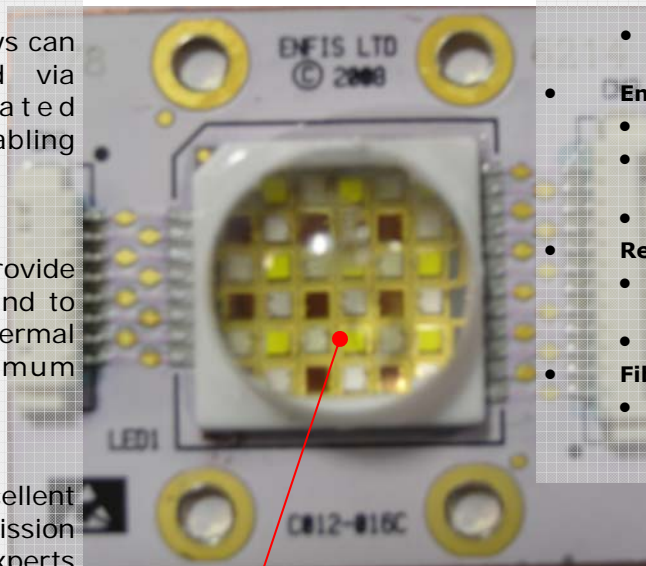

The 1cm² Array:
36 high-power LEDs
Mixing RGBW



ENFIS LIMITED
Technium 2, Kings Road,
Swansea Waterfront,
Swansea, SA18PJ, UK
Tel +44 (0)1792 485660
Fax +44 (0)1792 485537
www.enfis.com
info@enfis.com





ENFIS UNO Plus Dome Array RGBW (Vivid Blue)

Technical Specification

Electro-Optical Characteristics

Channel	Red			Green			Blue			White		
Item	Min	Typ	Max	Min	Typ	Max	Min	Typ	Max	Min	Typ	Max
Rated Current If (mA)		500			400			400			400	
Forward Voltage Vf (Volts)	20	24	28	26	32	36	28	32	36	27	31	35
Peak Wavelength λ_p (nm)	620	630	640	510	520	530	445	450	455			
Dominant Wavelength λ_d (nm)	610	620	630	518	528	538	450	455	460			
Spectral Width $\Delta\lambda$ (nm)	12	16	20	32	37	42	15	20	28			
Colour Temperature CCT (K)										4000	4500	5000
Total Radiant Flux Φ_R (mW)	2500	3000		1000	1400		2500	3500				
Radiant Flux Density Φ_R/A (mW/cm ²)	2174	2609		870	1220		2170	3130				
Total Luminous Flux Φ_L (Lumens)	400	500		450	570		80	110		450	550	
Luminous Flux Density Φ_L/A (lm/cm ²)	348	435		390	500		70	96		390	480	
Total Electrical Power P (W)		12.5			12.5			12.5			12.5	

All measurements performed at a heatsink temperature of 25°C and each Channel is capable of up to 20W for increased light output

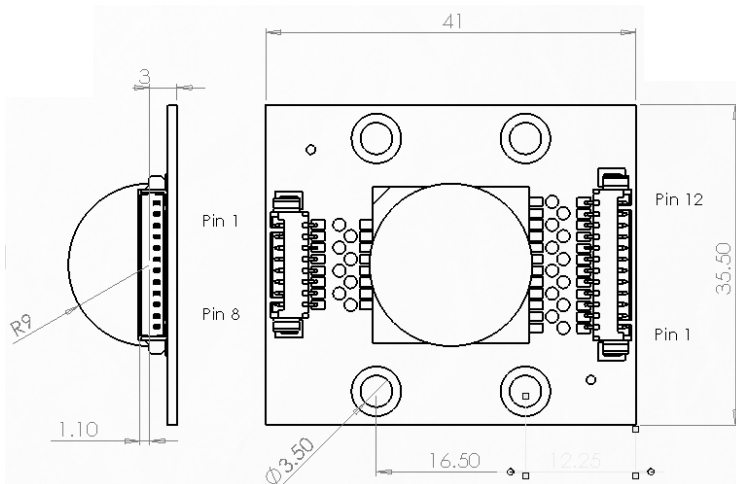
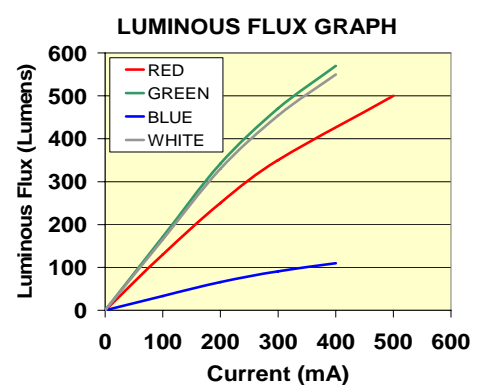
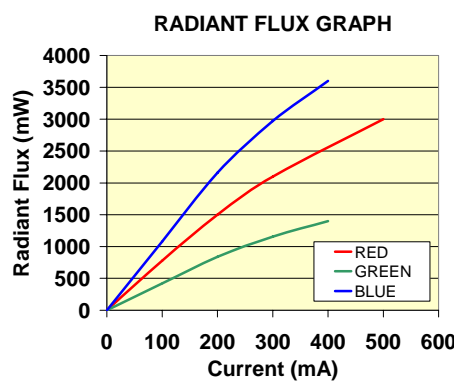
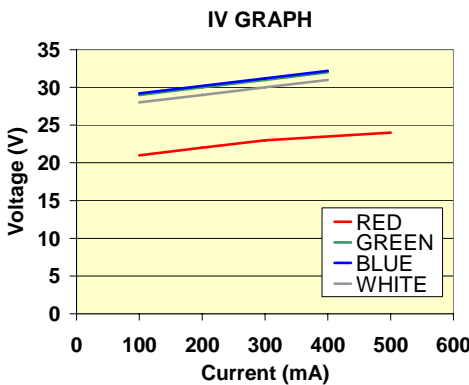

Heat Generation

Proper thermal design of the end product is of paramount importance. The operational junction temperature of each LED chip should be kept below 125°C.

Please contact Enfis for further support in this matter.

Handling LED Array

Contact with the encapsulation on the surface of the LED array must be avoided to prevent damage.

Do not apply pressure to the encapsulation or allow it to come into contact with sharp objects.

During operation the encapsulation will be hot and contact should be avoided.

Static Electricity

Care must be taken when handling, these products are sensitive to static electricity. Observe static handling precautions.

Cleaning

Avoid touching the LED array surface.

To clean—Blow surface with either dry air or nitrogen gas



Eye Safety Precautions

The light output of the products may cause injuries to human eyes in circumstances where the products are viewed directly with unshielded eyes for more than a few seconds.

Please refer to IEC 60825-1:2001 for further information



ENFIS LIMITED
 Technium 2, Kings Road,
 Swansea Waterfront,
 Swansea, SA18PJ, UK
 Tel +44 (0)1792 485660
 Fax +44 (0)1792 485537
 www.enfis.com
 info@enfis.com

